

Instruction Manual

G.R.A.S. 14AA Electrostatic Actuator Amplifier



Revision History

Any feedback or questions about this document are welcome at gras@gras.dk.

Revision	Date	Description
1	23 May 2007	First publication
2	4 November 2013	Updated connection diagrams and specifications
3	30 January 2014	AC output specified as V RMS.
4	1 October 2015	Correction to Fig 2.

Copyright Notice

© 2014-5 G.R.A.S. Sound & Vibration A/S

<http://www.gras.dk>

Any technical documentation that is made available by G.R.A.S. is the copyrighted work of G.R.A.S. and is owned by G.R.A.S.

The content in this document is subject to change without notice. G.R.A.S. Sound & Vibration A/S is not liable or responsible for any errors or inaccuracies that may appear in this document.

Trademarks

Product names mentioned in this document may be trademarks or registered trademarks of their respective companies and are hereby acknowledged.

Contents

Introduction.....	4
Setting the Mains Voltage.....	6
Driving a Microphone as Sound Source.....	7
Electrostatic Calibration of Microphones	8
Technical Specifications	9
The AC Outputs for Microphones and Electrostatic Actuator	9
Other Specifications	12
Accessories	12
Calibration, Warranty and Service	13
Calibration.....	13
Warranty.....	13
Service and Repairs.....	13

Introduction

The G.R.A.S. 14AA Electrostatic Actuator Amplifier is a high gain, high voltage amplifier. The output AC signal can be superimposed on either a 200 VDC or a 800 VDC signal. With the 200 V DC polarization voltage a standard measurement microphone as for example G.R.A.S. 40AF 1/2" Ext. Polarized Free-field Microphone, High Sensitivity can be used as a precision sound source for high frequency signal generation.

The 800 VDC polarization voltage can be used with the G.R.A.S. RA0014 1/2" and RA0015 1" Electrostatic Actuator for frequency response calibration to accurately measure the frequency response of microphones.

The input signal to the 14AA is supplied via a standard BNC connector and can be any signal up to 1V RMS. The input signal is amplified 40 dB (100 times) in the 14AA for a maximum output signal of 100 V RMS. The 14AA has three output connectors: AC output, AC + 200 VDC output and AC + 800 VDC output.



Fig. 1. Electrostatic Actuator Amplifier 14AA

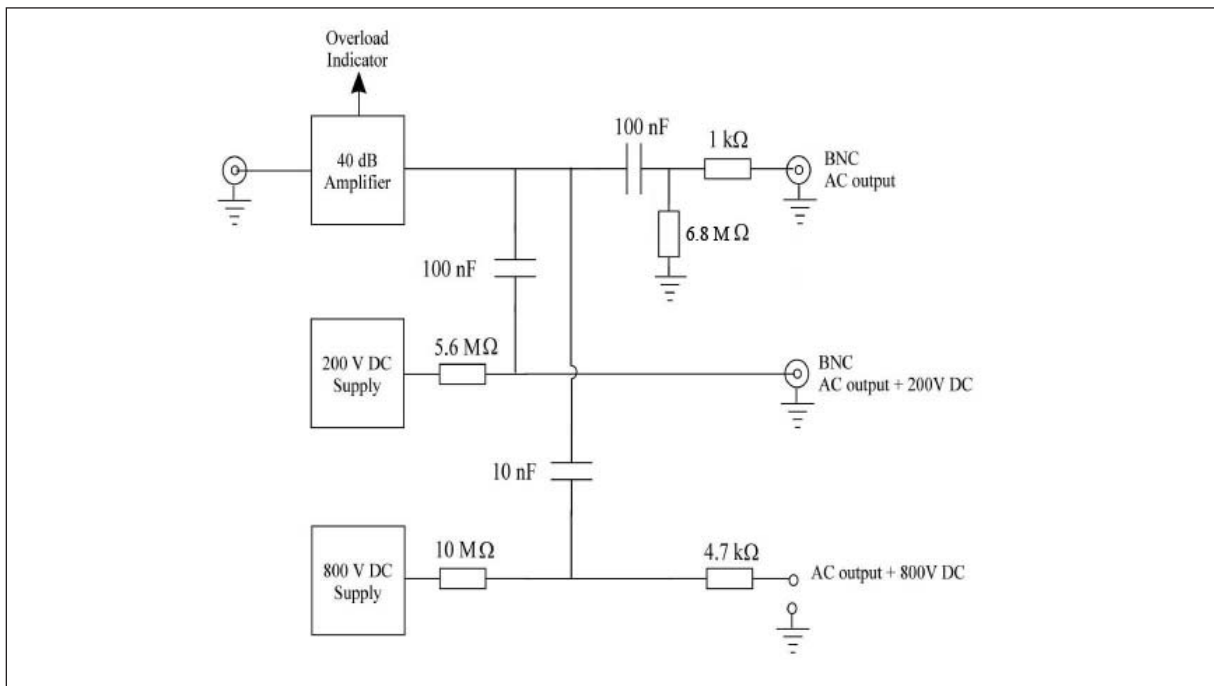

Fig. 2. 14AA principle.

The 14AA electrostatic actuator amplifier consists of a 40 dB gain, high voltage amplifier and two high voltage DC power supplies as shown in figure 2.

The input signal from the BNC connector on the front panel goes to the amplifier stage. The input signal must be limited to maximum 1 V RMS in order not to overload the amplifier. If the signal exceeds 1 V RMS, the overload indicator on the front panel will light up.

The input signal is amplified by 40 dB and the output signal is going to the three output connectors : AC Output, AC Output + 200 VDC and AC Output + 800 VDC.

The AC Output is the output from the 40 dB gain amplifier. For an input signal of 1 V RMS the output signal will be 100 V RMS. This signal can be used for driving prepolarized microphones as sound sources.

The AC Output +200 VDC is the output from the 40 dB gain amplifier superimposed on a 200 VDC polarization voltage. For an input signal of 1 V RMS the output signal will be 100 V RMS. This signal can be used for driving externally polarized microphones as sound sources.

The AC Output +800 VDC is the output from the 40 dB gain amplifier superimposed on a 800 VDC polarization voltage. For an input signal of 1 V RMS the output signal will be 100 V RMS. This signal can be used for driving electrostatic actuators for recording the pressure response of measurement microphones.

Setting the Mains Voltage

Before connecting the 14AA to the mains power the voltage setting on the rear panel of the 14AA should be set to the correct local mains power voltage. The voltage setting is indicated in the Voltage setting indicator on the rear panel, see figure 3. To change the setting, remove the fuse holder by inserting a small screwdriver in both sides of the fuse holder as indicated in figure 4.



Fig. 3. The voltage setting indicator.

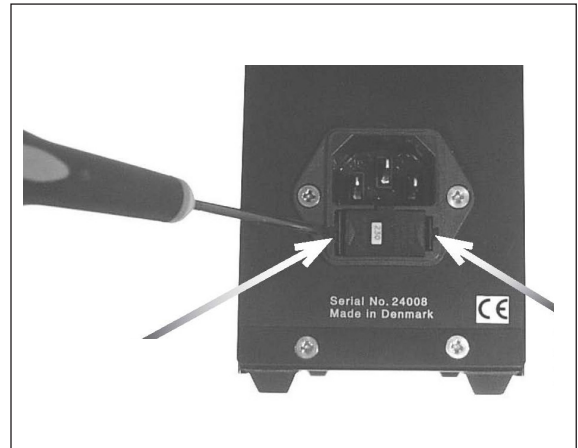

Fig. 4. Removing the fuse holder.

Remove the fuse insert as indicated in figure 5a and rotate it 180 degree. Insert the fuse insert and put the fuse back in. Insert the fuse holder in the 14AA. The voltage setting indicator should now indicate the new setting of the mains supply voltage.

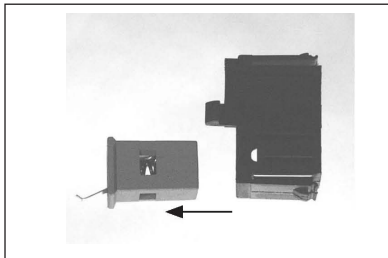

Fig. 5. Remove the fuse insert from the fuse holder.

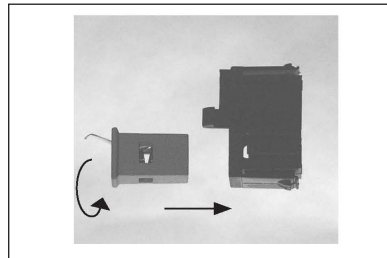

Fig. 6. Rotate the fuse insert 180 deg and insert it again.

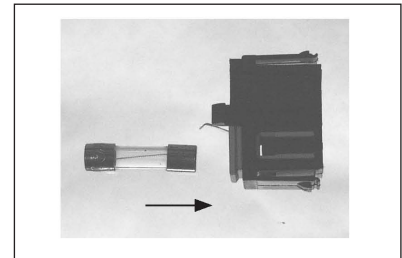

Fig. 7. Insert the fuse in the fuse holder.

Driving a Microphone as Sound Source

The 14AA Electrostatic actuator amplifier can be used for driving a microphone as a precision sound source, for example for frequency calibration of an Ear Simulator. When used as a sound source in accordance with the guidelines laid out in IEC 60318, the sensitivity of the transmitter microphone can be assumed to be identical to its response as a receiver.

A signal generator is connected to the input BNC connector of the 14AA and the output is connected to a transmitter adapter.

Two transmitter adapters are available for 1/2" and 1/4" microphones respectively:

- **1/2" microphone:** Transmitter adapter RA0067 and BNC-BNC cable AA0032.
- **1/4" microphone:** Transmitter adapter RA0086 and BNC-Microdot cable AA0073-05.

If the microphone is an externally polarized microphone like the G.R.A.S. 40BP 1/4" Pressure Microphone, the RA0086 should be connected to the *AC Output +200 VDC*. If the microphone is a prepolarized microphone like the G.R.A.S. 40BD 1/4" Pressure Microphone, the RA0086 should be connected to the *AC Output*.

Important. Short cable lengths (0.5 m) between 14AA and the transmitter adapter must be used. Longer cables will impair the high-frequency performance. For further information, see "Technical Specifications" on page 9.

An example of the electrical connections needed for a frequency calibration of an ear simulator is shown in Fig. 8. For a detailed information about how to calibrate an RA0045 Ear Simulator, refer to the documentation for the RA0045 and the recommendations of IEC 60318.

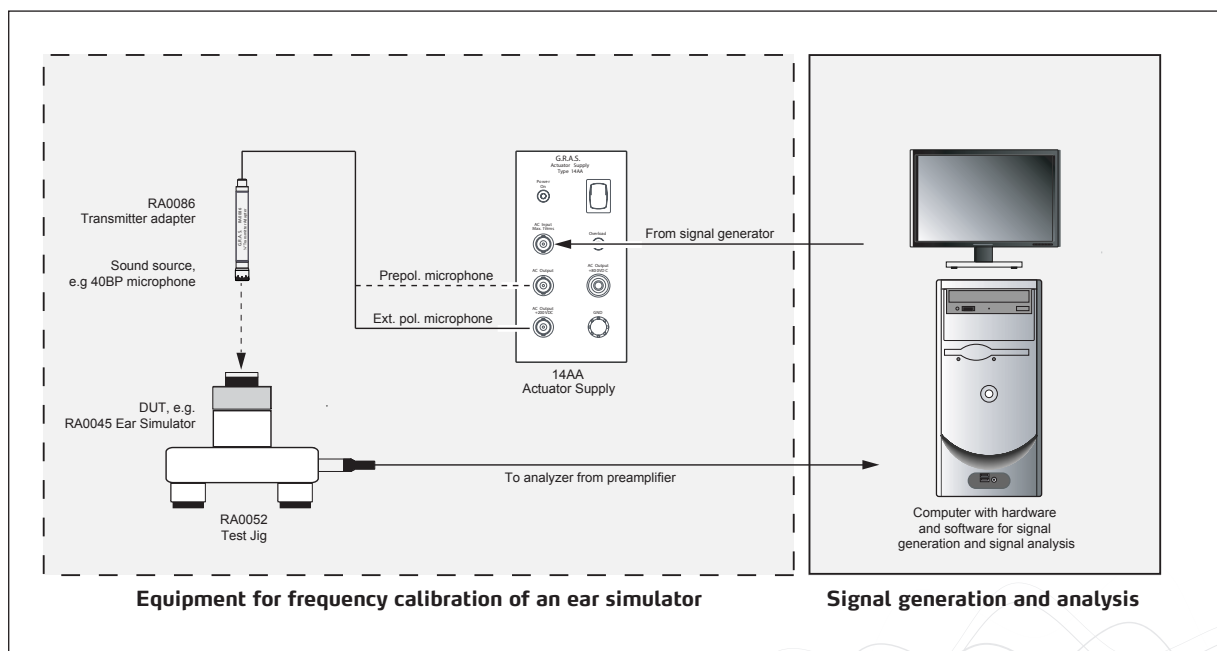

Fig. 8. A setup for frequency calibration of an IEC60318-4 Ear Simulator.

Electrostatic Calibration of Microphones

The 14AA Electrostatic actuator amplifier can be used for driving an electrostatic actuator for recording the frequency response of measurement microphones. The measurements can for example be performed with a general purpose frequency analyzer with built-in signal generator.

The output of the signal generator is connected to the input of the 14AA. The electrostatic actuator is mounted on the microphone diaphragm and connected to the *AC Output +800 V DC* output connector. The output signal from the microphone preamplifier is going to the input of the signal analyzer. The frequency response can then be recorded by a sweep or by a noise excitation with FFT analysis.

Two different electrostatic actuators are available:

- **1" microphones:** G.R.A.S. RA0015 1" Electrostatic Actuator for frequency response calibration.
- **1/2", 1/4" and 1/8" microphones:** G.R.A.S. RA0014 1/2" Electrostatic Actuator for frequency response calibration. (Adapters for 1/4" and 1/8" microphones are included with the actuator).

Fig. 9 shows a block diagram showing a setup using the 14AA for frequency calibration with an electrostatic actuator.

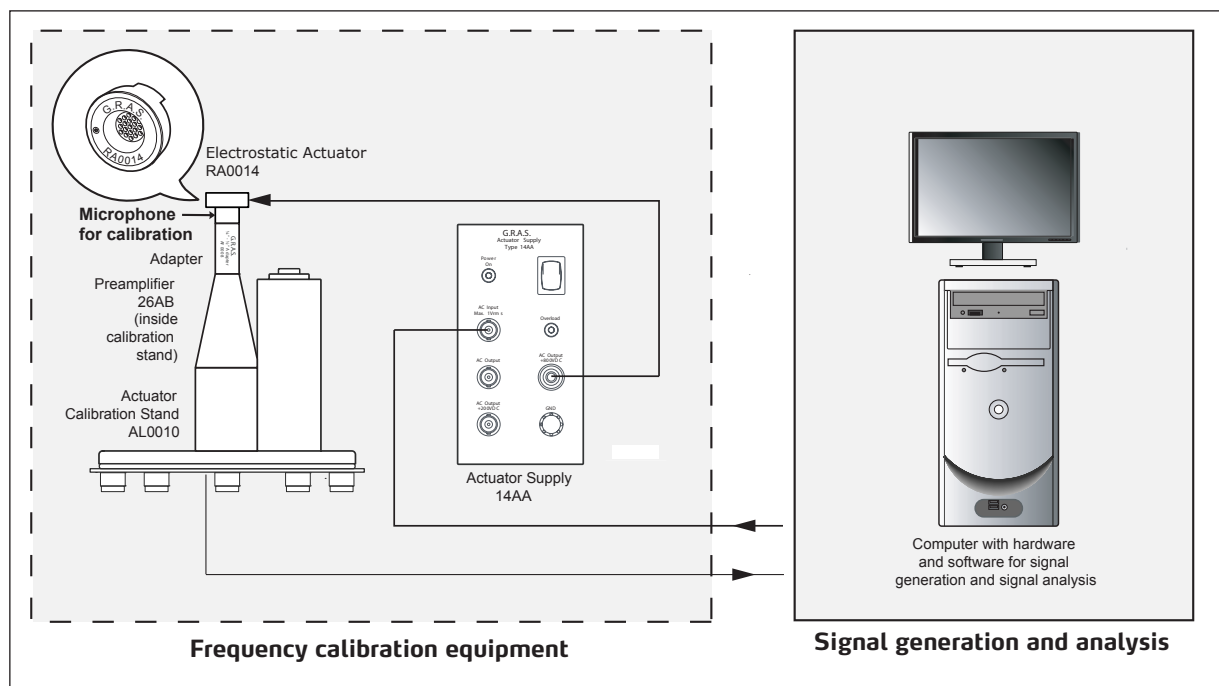

Fig. 9. Block diagram of a calibration setup using an electrostatic actuator.

Technical Specifications

The AC Outputs for Microphones and Electrostatic Actuator

Under open loop conditions, the AC outputs of the 14AA are linear to over 200 kHz. However, the cable connected to the output limits the high-frequency performance in the same way as a low-pass filter. The longer the cable, the lower the cut-off frequency. If you need to measure at very high frequencies, you must use the shortest cable possible. When the high-frequency roll off is known, you can use it as a correction factor.

The AC Output (0 VDC for prepolarized microphone)

Output Signal, max level peak-to-peak	100 V RMS
-3 dB Low Frequency Cut-off	
Open loop	0.35 Hz
1 M Ω load	1.9 Hz
Frequency Response, 1 meter RG-58 cable (~100 pF), 100 V RMS	
± 0.1 dB	25 – 50 kHz
± 1 dB	10 – 100 kHz
Max Output Current	5 mA AC

The AC Output +200 VDC (for externally polarized microphone)

Output Signal	100 V RMS
-3 dB Low Frequency Cut-off	
Open Loop	0.3 Hz
1 M Ω load	1.8 Hz
Frequency Response, 1 meter RG-58 cable (~100 pF), 100 V RMS	
± 0.1 dB	25 – 50 kHz
± 1 dB	10 – 100 kHz
Max Output Current	5 mA AC
DC Output Impedance*	5.6 M Ω

* See also schematic drawing in Fig. 2

Typical Frequency Response for the AC Outputs, 0 VDC and + 200 VDC

RG58 Cable, 1 Meter

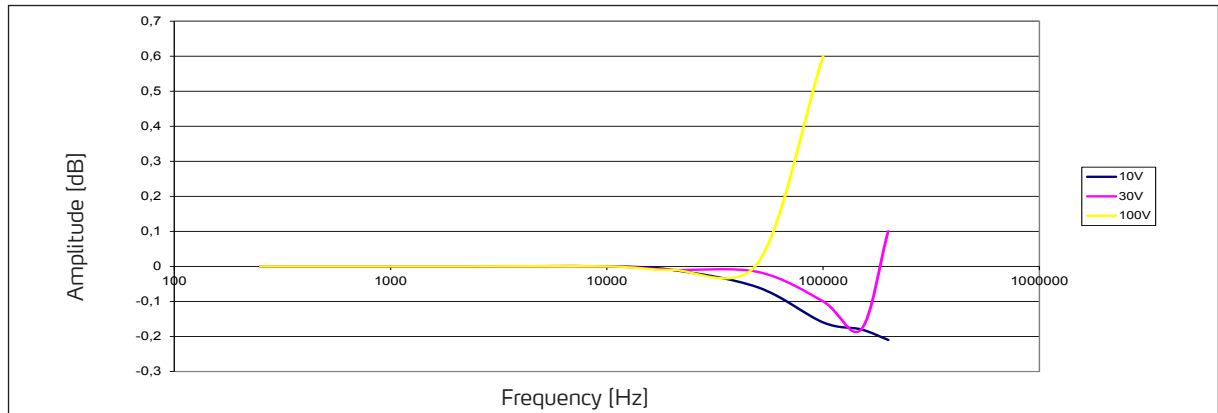

Fig. 13. The Frequency response for the 0 VDC and 200 VDC outputs, 1 meter RG58 cable, 10, 30 and 100 V RMS.

RG58 Cable, 3 Meters

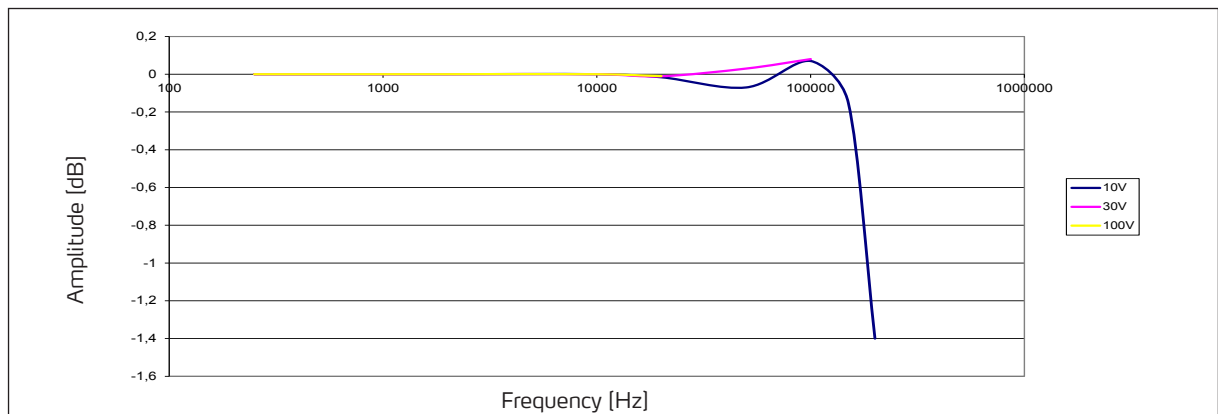

Fig. 14. The Frequency response for the 0 VDC and 200 VDC outputs, 3 meter RG-58 cable, 10, 30 and 100 V RMS.

RG58, Maximum Cable Lengths

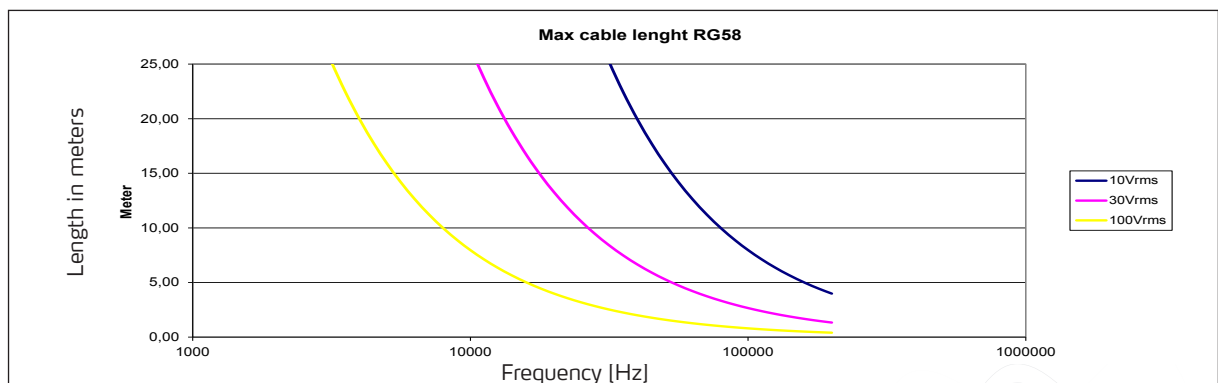

Fig. 15. The obtainable high-frequency response as function of cable length and signal level.

The AC Output +800 VDC (for electrostatic actuator)

Output Signal	100 V RMS
-3 dB Low Frequency Cut-off	
Open loop	1.6 Hz
1 M Ω load	17.5 Hz
Max. Frequency at 100 V RMS output	
with RA0014 1/2"	200 kHz
with RA0015 1"	50 kHz
Max Output Current	2.5 mA AC
DC Output Impedance*	10 M Ω

* See also schematic drawing in Fig. 2

Other Specifications

Input signal	1 V RMS
Gain	40 dB
Output signal	100 V RMS
Actuator Polarization voltage	800 V DC
Microphone Polarization voltage	200 V DC
Temperature Range	-15 °C to 45 °C
Power supply	110-130 V AC or 220-240 V AC
Power consumption	15 VA
Fuse	125 mA (Fast)
Weight	1400 g
Dimensions	
height	137 mm
width	70 mm
length	200 mm

Accessories

The following items can be ordered separately.

Item	Part Number
1/2" Electrostatic Actuator	RA0014
1" Electrostatic Actuator	RA0015
1/2" Microphone Output Adapter	RA0068
0.5 m BNC Cable	AA0032
1 m BNC Cable	AA0033

Calibration, Warranty and Service

Calibration

Before leaving the factory, all G.R.A.S. products are calibrated in a controlled laboratory environment using traceable calibration equipment.

We recommend a yearly recalibration at minimum, depending on the use, measurement environment, and internal quality control programs.

We recommend calibration prior to each use to ensure the accuracy of your measurements.

Warranty

All G.R.A.S. products are made of high-quality materials that will ensure life-long stability and robustness. The 14AA is delivered with a 2-year warranty.

Damaged diaphragms in microphones can be replaced.

The warranty does not cover products that are damaged due to negligent use, an incorrect power supply, or an incorrect connection to the equipment.

Service and Repairs

All repairs are made at G.R.A.S. International Support Center located in Denmark. Our Support Center is equipped with the newest test equipment and staffed with dedicated and highly skilled engineers. Upon request, we make cost estimates based on fixed repair categories. If a product covered by warranty is sent for service, it is repaired free of charge, unless the damage is the result of negligent use or other violations of the warranty. All repairs are delivered with a service report, as well as an updated calibration chart.

Manufactured to conform with:

CE marking directive:
93/68/EEC



WEEE directive:
2002/96/EC



RoHS directive:
2002/95/EC



G.R.A.S. Sound & Vibration continually strives to improve the quality of our products for our customers; therefore, the specifications and accessories are subject to change.